

施工サイクル

① 掘削・排土

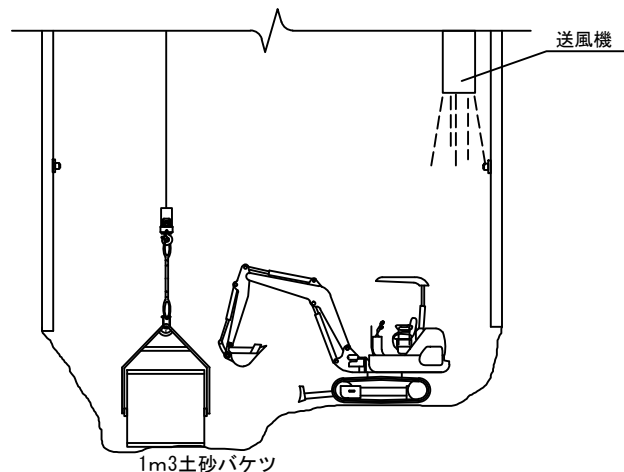

② 杭壁整形・金網取付

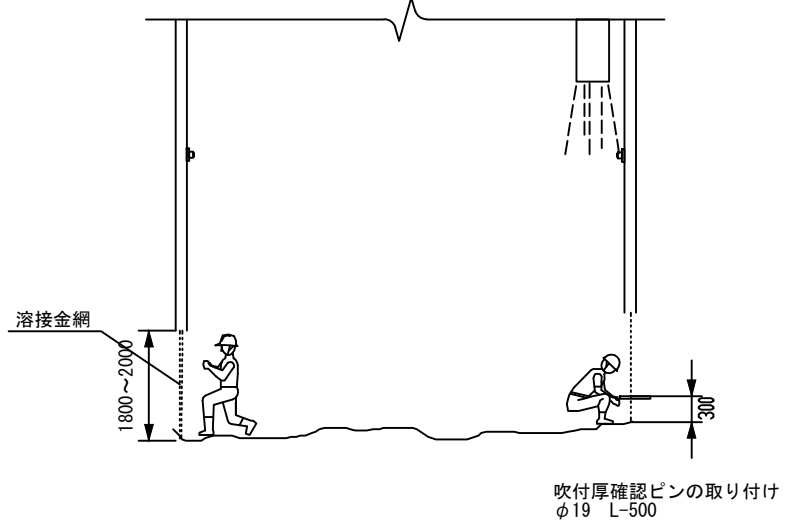

③ 吹付

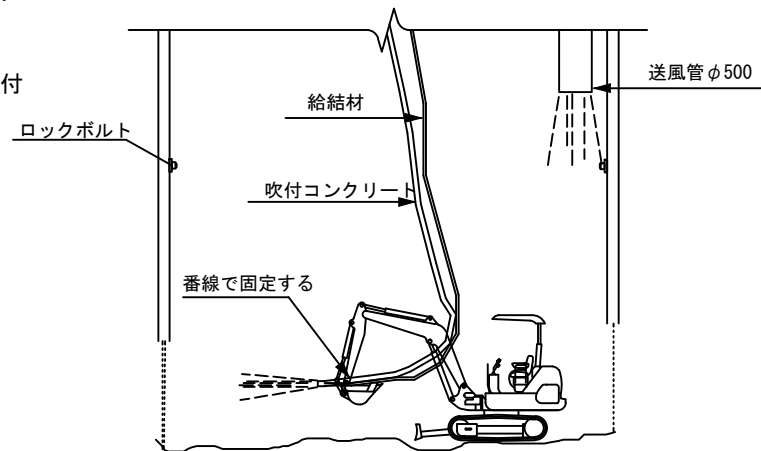

④ RB削孔

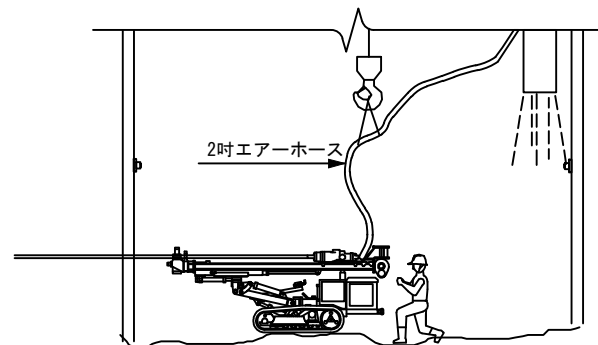

⑤ モルタル注入・RB挿入

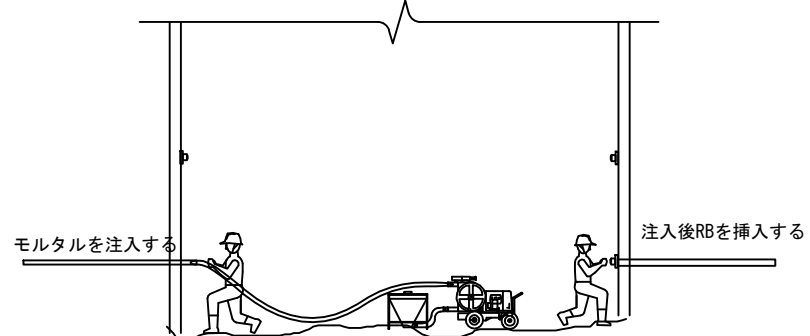

平面図

側面図

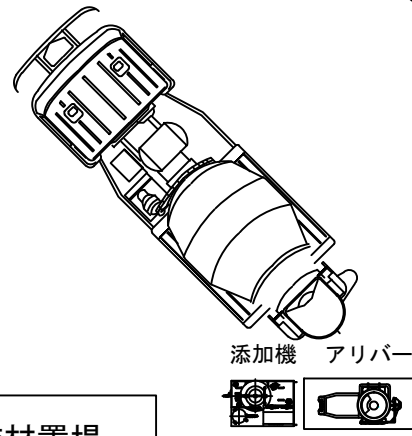
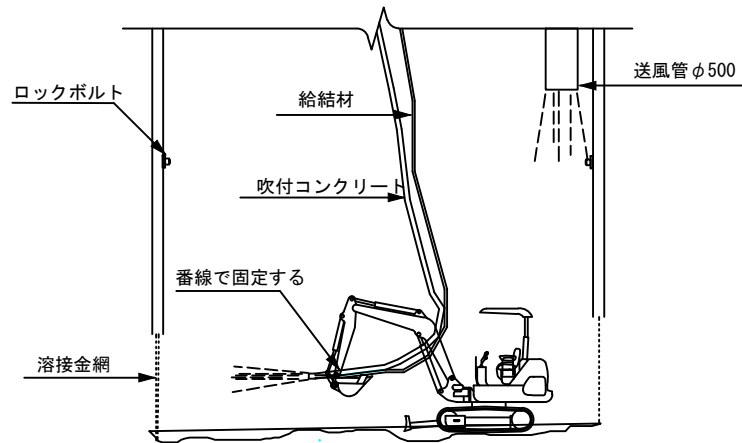
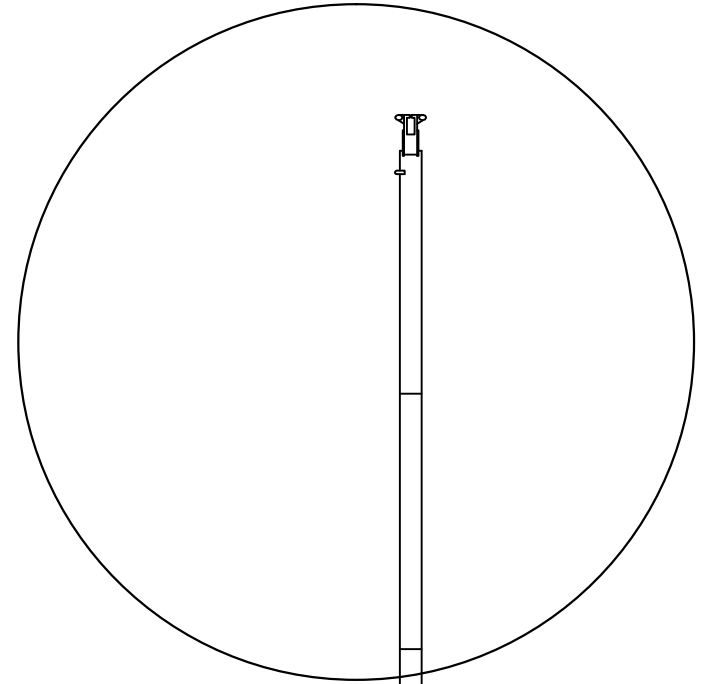
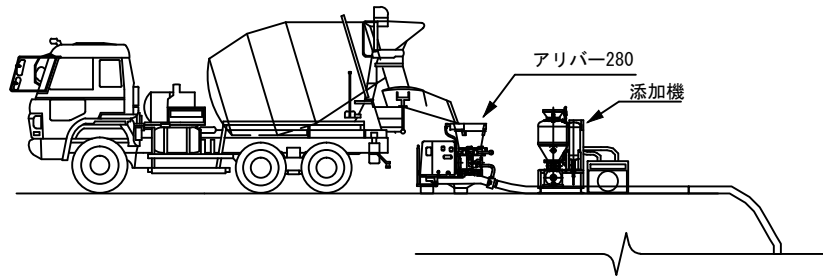

急結材置場

PDS655